

 **CAMEL** [®] 

DYC1535



- Precise lifting and lowering via hand lever. Battery cut -off key switch prevents unauthorized use.



- Additional protection for the operator through foot protection on the steering rollers. Safe parking in any situation with mechanical parking brake.



- Integrated 120AH(150AH option) maintenance-free battery supplies strong power to effect frequent lifting tasks, external charger facilitates easy and reliable charging of the integrated battery.



**RELIABLE &
ECONOMIC**

DYC1535

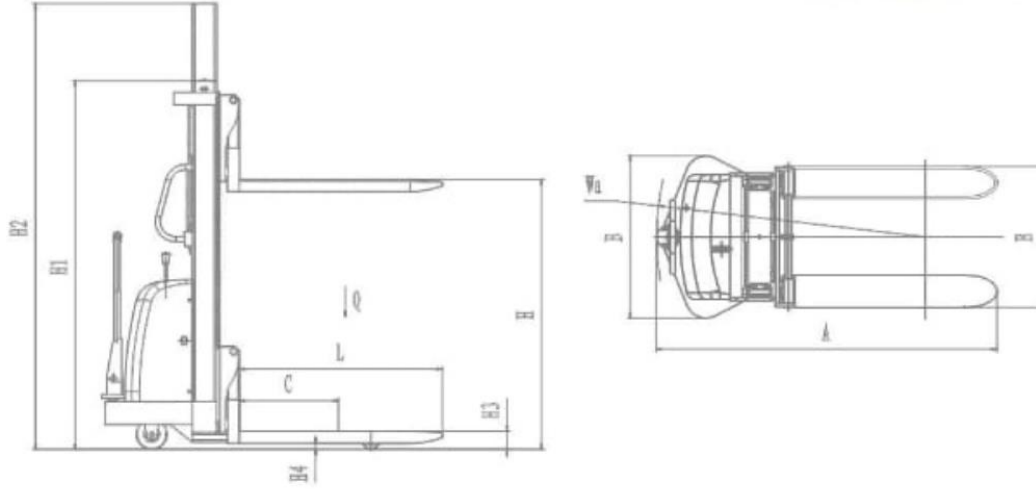

DYC1535	Model	الموديل
1500	kg Max. Loading	الحمولة القصوى
83/3500	mm Min/Max Fork height	أدنى/أقصى ارتفاع للشوكة
60/180/1150	mm Fork Dimension s/e/l	أبعاد الشوكة
320 ~ 680	mm Fork Overall Width	العرض الكلي للشوكتين
0.08 / 0.15	m/s Lift Speed (laden/unladen)	سرعة الرفع محمل/فراغ
12 / 120	V/Ah Battery	البطارية
1.5	Kw Motor	الموتور
179 x 64 x 233	cm Overall Dimensions l x w x h	الأبعاد الكلية
N/A	Platform	منصة الوقوف
N/A	Protection Arms	أفرع للحماية
480	kg Own Weight	وزن القطعة

