



[www.gestled.com](http://www.gestled.com)

# NEW HIGH BAY LUMINAIRE



## APPLICATIONS:

- Factories
- workshop
- halls
- storage rooms
- hangers
- warehouse, etc.

## BENEFITS:

- Lightweight design.
- High light survival factor (LSF).
- Instant illumination.
- Low heat.
- Energy saving.
- Easy maintenance.
- Warranty 3 years.

## FEATURES:

- Weight 3.15 KG.
- Lumen efficiency 130 LM/W.
- IP rated 65.
- Aluminum die cast body.

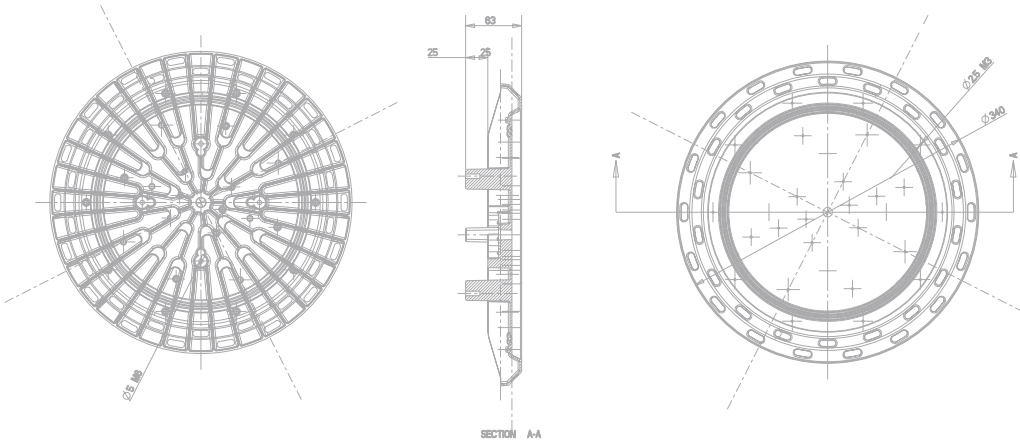

## HIGH BAY SPECIFICATIONS

WATT	LUMEN	LED	DRIVER	POWER FACTOR	CCT	CRI
100	13000	Lumiled	ZH GP	≥ 0.95	6500K	≥70
150	19500					
200	26000					



**NEW HIGH BAY LUMINAIRE**